

6		7		8	
NO	Revision notes	Version	Designed by	Checked by	Date
1	Now	A0	Kerry Pan	Lowry Lau	2021.08.21

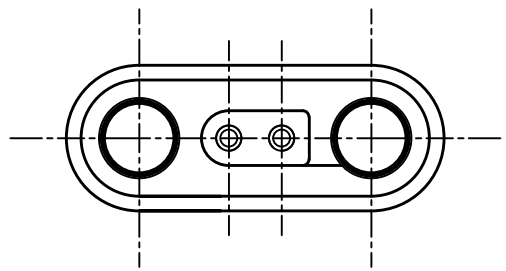

Note(注):

- Material and coating conform to ROHS and REACH standards (材料和涂层符合ROHS和REACH标准)
- @Key inspection dimension (@为重点检验尺寸)

Electrical(电气性能):

- Rated voltage: DC 12V ; Rated voltage: 5A Max. (额定电压: DC 12V 额定电流: 最大5A)
- Contact resistance of spring pin : 50 milliohm Max. (单针接触阻抗: 最大50毫欧姆)
- Adsorption capacity test:The male docking adsorption is 550g±20% (吸附力测试: 公端对接吸附力为550g±20%)
- This product adopts molding method, has good waterproof and dustproof performance, the protection level is IP68 (本产品采用模内成型方法, 具有良好的防水和防尘性能, 防护等级为IP68)

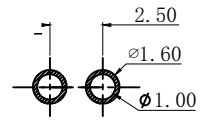
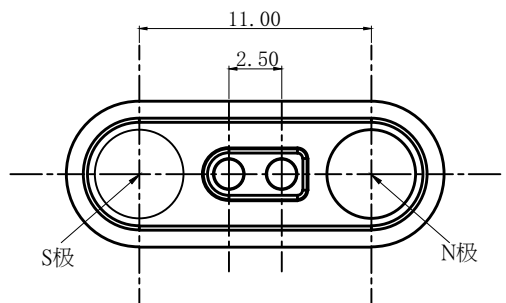
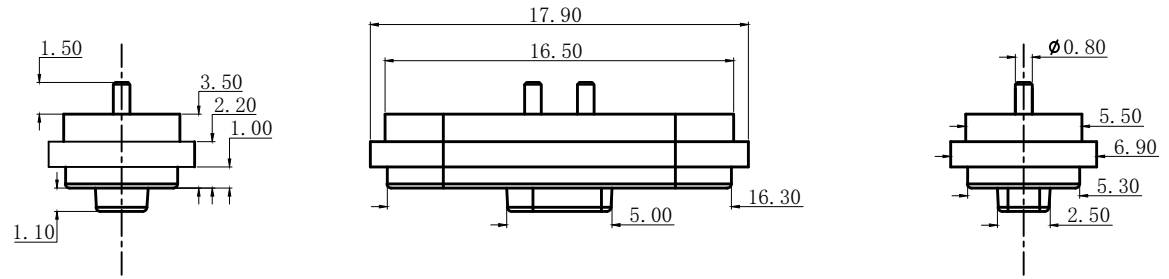

Recommended pcb layout (推荐PCB布局)
layout tolerance: ±0.05mm (布局公差: ±0.05mm)

产品结构:

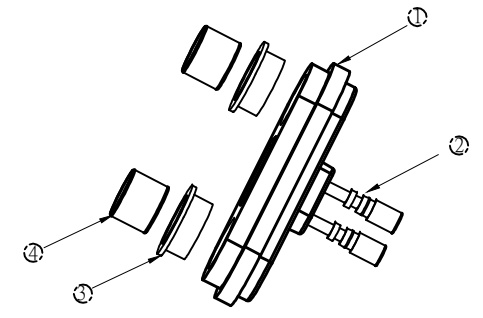

④	磁铁	钕铁硼 N52 表面镀镍60-100u	银色	200M-210A
③		铜套 黄铜C3602 表面镀镍60-100u	银色	
②	弹簧针连接器	车针 黄铜C3604 表面镀金5u	金色	ST-200-B02-21
①		成型 高温尼龙 HTN UL94 V-0	黑色	200-M01-B02

NO.	名称	规格		颜色	模具	备注
Angle	±2°	Size	A4	company name 东莞市振炫精密电子有限公司 Dongguan Zhenxuan Precision Electronics Co.,Ltd	Product Number SM-200-B02-21	
0°~6	±0.10	Unit	mm			
6°~30	±0.20	View				
30°~120	±0.30	Scale	1 : 1			

原料号: TS200AF0201